



WASTE INITIATIVES

New Technology for an Age Old Problem

CONTENTS

- Waste Initiatives Company Profile
- Introducing Allegheny
- Product Overview
- Product Specifications
- Complete Concept Systems
- Training and Safety



Company Profile

Waste Initiatives is an Australian owned business with over 30 years experience supplying high quality waste management equipment.

Our range represents the latest waste technology available in the world today.

We have provided companies all over Australia and New Zealand with solutions to efficiently manage their waste.

It's our attention to detail, that makes the difference.

Our equipment range represents the latest in technology available in the world today. Backed/supported by extensive research, development, practical experience, reliable maintenance, comprehensive parts and service back up.



**WASTE
INITIATIVES**

Introduce...



AlleghenyShredders

THE SHREDDING INDUSTRY ICON SINCE 1967

Waste Initiatives Introducing Allegheny

Allegheny Overview



Allegheny designs, engineers and manufactures its equipment to withstand the most demanding applications. They use only the highest quality materials to ensure that our shredders, grinders, balers, etc. are the most reliable and long-lasting in the industry a premier manufacturer of high capacity shredding systems for over 40 years.

The result? A truly enviable record of reliability:

- 94% of all Allegheny equipment bought 12 years ago is still on the job today!
- Built by skilled craftsmen utilizing state-of-the-art computer-aided design and manufacturing (CAD/CAM)
- Highest capacity throughput, from 220kgs/hr. to 25 tons/hr.
- Solid steel cutters and combers, virtually indestructible and resistant to damage and wear
- All covers, frames, base assemblies, spur/drive gears, shafts, end plates, etc. manufactured from the highest quality American-made steel
- Heavy-duty drive trains using Dodge-Reliance shaft-mounted gear reducers
- Designed for ease of maintenance and servicing to avoid costly downtime
- Unique safety features to ensure safe, reliable operation

Waste Initiatives Product Overview

Allegheny Paper Shredders

Click to view



ALLEGHENY PAPER SHREDDERS CORPORATION
The unchallenged world leader in high capacity destruction systems

Total Shredding Solutions

powered by Allegheny

**Paper Shredders • Security Grinders
Pierce & Shear Shredders
Product Destruction Shredders
Mobile • Plant-based**

The image features a central graphic of a globe with a lightning bolt striking it, set against a background of shredded paper. The globe is partially covered in green foliage, and the lightning bolt is bright yellow and white. The text 'powered by Allegheny' is written in a stylized, white font across the globe. The overall background of the slide is a dark blue with a grid pattern.

Waste Initiatives Allegheny Products

Product Specifications



16 Series

(click on image to view specifications)

100 Series

(click on image to view specifications)



Waste Initiatives Allegheny Products

Product Specifications



1000 Series

(click on image to view specifications)

Waste Initiatives Complete Concept Systems

The Complete Solution

*Shredding Systems for
Security Shredding > Product Destruction > Waste Reduction > Resource Recovery > Recycling*

Manage Your Waste Efficiently

Waste Initiatives supply and install the most efficient shredders, granulators, pulverisers, disintegrators, cutting mills, conveyors and balers, enabling us to provide complete Waste, Recycling and Waste Management solutions for the recycling of your Companies Waste, whether that be a single stream or multiple streams. ie;

- Paper – recycling and document destruction, security shredding
- Municipal and organic food waste, paper, cardboard and green waste, back to a composted state.
- Plastic applications – Regranulation – (In House) Recycling – Volume Reduction (transportation costs)
- Wood Waste – Utilisation of waste wood from sawmills, joiners and carpenters workshops to generate heat for buildings, drying chambers, energy plants, or bark mulch
- A full list of materials and applications is listed below

Benefit when designing your system from the outstanding long-term relationships we have with leading manufacturers of charging systems, heating systems, conveyor systems, granulators, cyclones and suction systems

At the same time, considering the Environmental Issues and ensuring that All Health and Safety requirements are met.

Waste Initiatives Complete Concept Systems

Maximise your returns Minimise your costs

Industrial shredder applications

Abattoirs	Glass	Paper
Automotive	Hospital/Clinical	Plastics
Bank Notes	Industrial	Textiles / Carpet
Cardboard / Packaging	Metals	Timber / Bark
Electrical / Electronic	Municipal / Bio Waste	Tyres / Rubber
Food / Catering	Pharmaceutical / Health Care	
Whitegoods		

Materials suitable for shredding

Aluminium	Glass	Metals
Cabling	Pharmaceutical	Steel Drums
Cardboard	Plastic Products	Textiles
Carpet	Plastic Purging	Waste Timber
Computer Hard drives	Rubber Tyres	& many more.....
General Waste	Sensitive Documents	

Waste Initiatives Complete Concept Systems

Concept Drawings

Process Plant

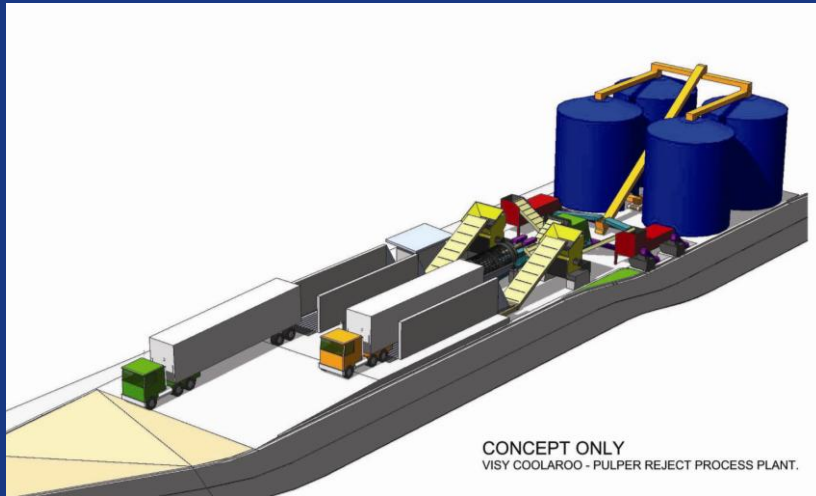

Containerised Recycling Process Plant

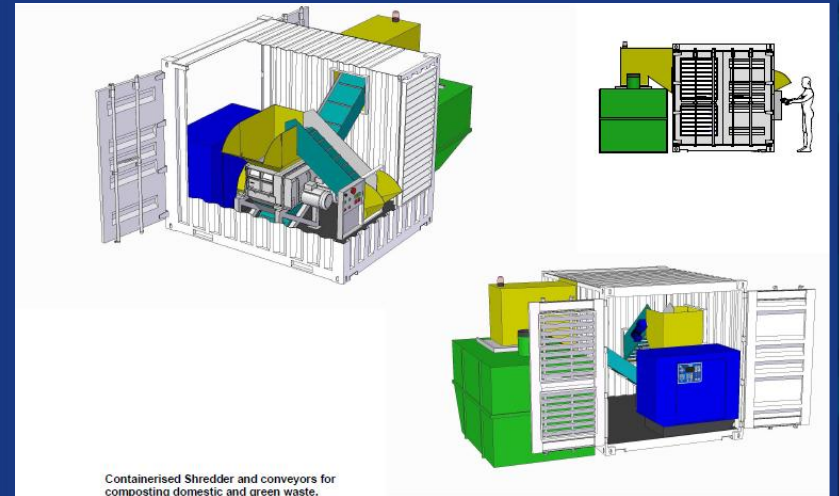

Secure Document Destruction System

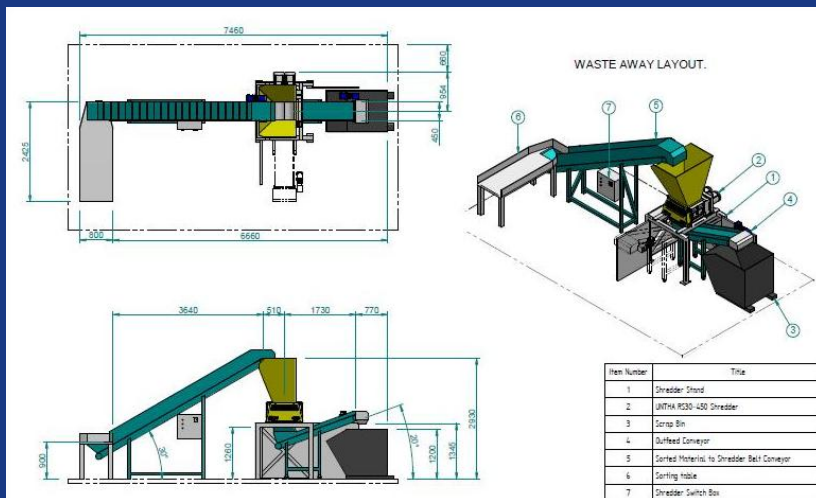

Baling Sorting System

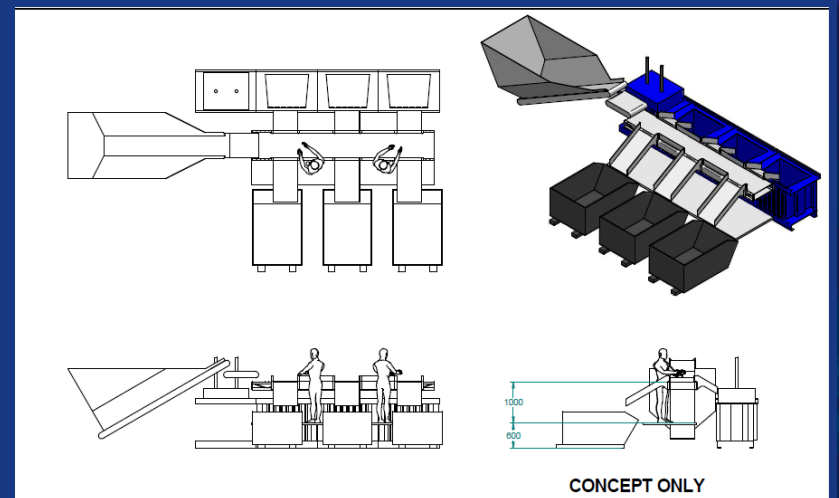

Waste Initiatives Training & Safety Training & Safety Overview

Waste Initiatives will install and commission each of its systems.

At the completion of the installation, Waste Initiatives will conduct comprehensive staff training for all personnel operating the system.

At the end of this training we issue a certificate to certify satisfactory compliance will all safety and operational aspects of the equipment.





WASTE INITIATIVES

FOR SALES & SERVICE AUSTRALIA WIDE CALL:

1800 44 11 00

or visit www.wasteinitiatives.com.au

From Concept to Complete Solution.

Call us today to discuss your requirements.





WASTE INITIATIVES

New Technology for an Age Old Problem